

mdss-1,2,5

the pacesetter in quality prefab roof products



245 eisenhower lane south • lombard, illinois 60148
 630.705.1920 • 800.243.3018 • fax 630.705.1930
 www.patecurbs.com • e-mail: sales@patecurbs.com

pate multiple duct support system

standard construction

Support Rail

Heavy ga. galvanized steel, unitized construction with internal base plate, continuous welded corner seams, pressure treated wood nailer, counterflashing with screws. Internally re-inforced to conform with **pate** load bearing factors.

Duct Mounting Hardware

Unistrut legs, support saddle and slides to allow for duct movement, vertical and horizontal adjustment.

p.o. no. _____
 customer _____

 project _____
 location _____

 architect _____
 engineer _____

pate duct support system

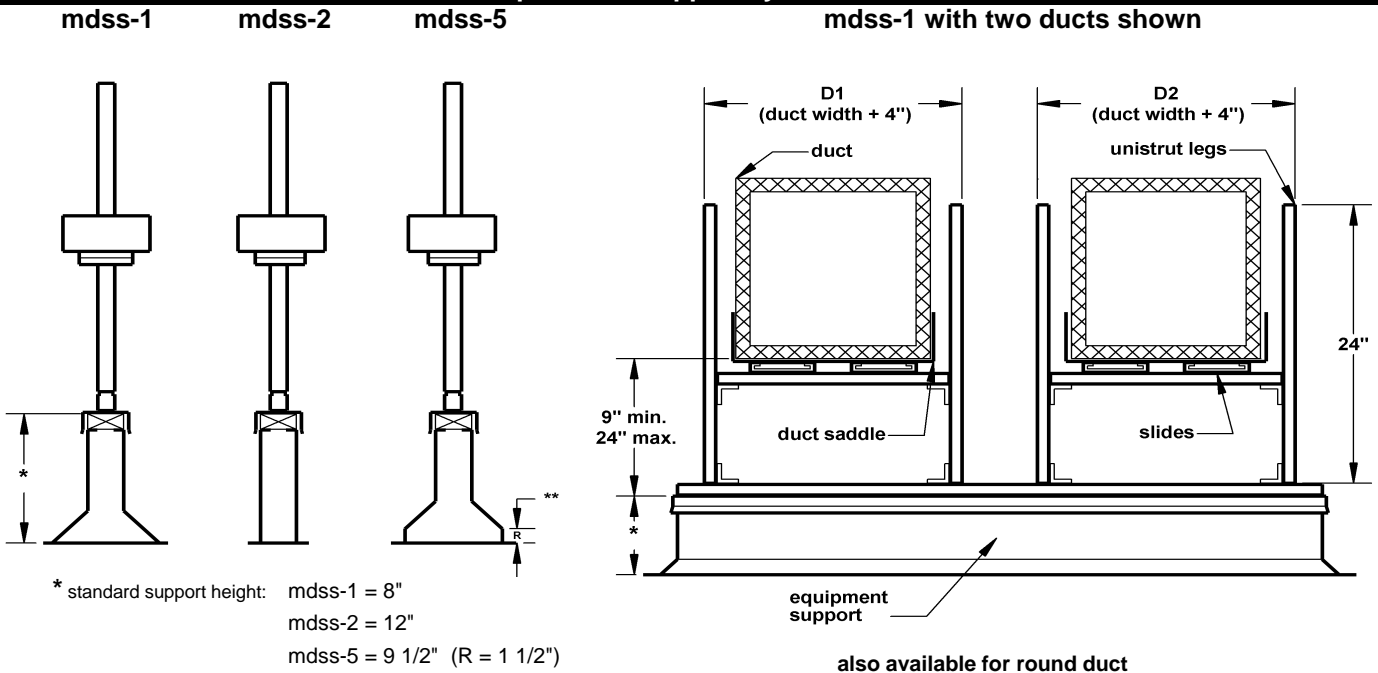

duct support system requirements

quantity	style	nailer length	nailer width	* overall height	D1	D2	duct size D1 W x H	duct size D2 W x H	# of ducts per rail	** raised cant height	tag