

dss-1,2,5

the pacesetter in quality prefab roof products



245 eisenhower lane south • lombard, illinois 60148
 630.705.1920 • 800.243.3018 • fax 630.705.1930
 www.patecurbs.com • e-mail: sales@patecurbs.com

**pate
 duct support system**

standard construction

Support Rail

Heavy ga. galvanized steel, unitized construction with internal base plate, continuous welded corner seams, pressure treated wood nailer, counterflashing with screws. Internally re-inforced to conform with **pate** load bearing factors.

Duct Mounting Hardware

Unistrut legs, support saddle and slides to allow for duct movement, vertical and horizontal adjustment.

Customer:

PO:

Project:

Address:

Address:

Notes:

pate duct support system

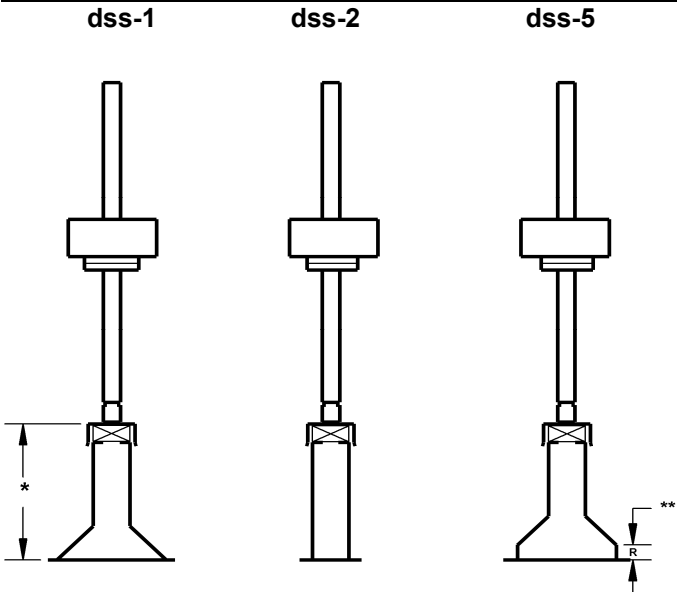

* standard support height: dss-1 = 8"
 dss-2 = 12"
 dss-5 = 9 1/2" (R = 1 1/2")

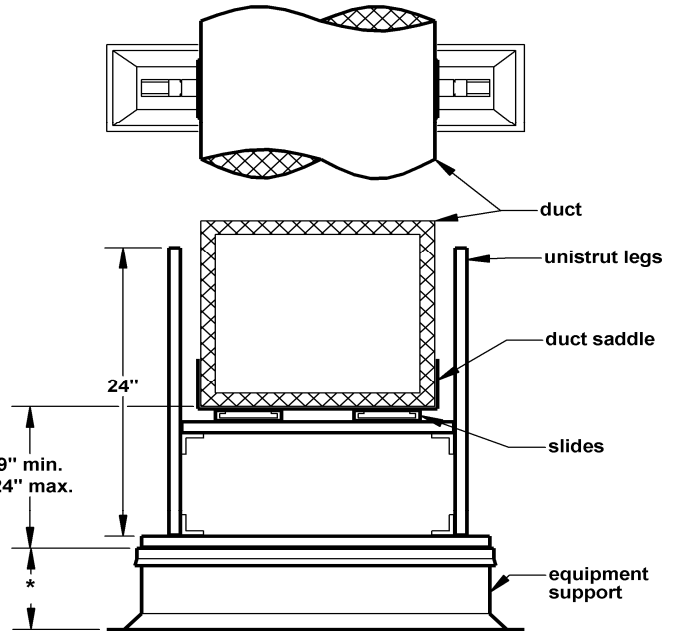

also available for round duct

duct support system requirements

quantity	style	nailer length	nailer width	* overall height	** raised cant height	duct size	square or round	tag